

Model: SF-101 Digital Temperature Controller

Refrigeration LED

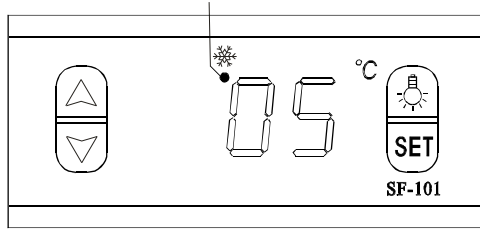

Features of Function

- It is a mini-sized and integrated intelligent controller
- Temperature Display/ Temperature Control /Light Control/ Value Storing / Self Testing /Parameter Locking

Specifications

1. Power supply:230VAC
2. Temperature sensor:NTC ,2m(L)
3. Range of temperature displayed: $-45^{\circ}\text{C} \sim 100^{\circ}\text{C}$ Accuracy: $\pm 1^{\circ}\text{C}$
4. Range of set temperature: $-45^{\circ}\text{C} \sim 45^{\circ}\text{C}$ Factory default: 4°C
5. Dimension:77(Length) \times 35(Width) \times 60(Depth)mm
Mounting hole dimension:71(Length) \times 29(Width)mm
6. Temperature of the operating environment: $-10^{\circ}\text{C} \sim 60^{\circ}\text{C}$
Relative Humidity:20%~90% (Non-condensing)
7. Relay output contact capacity:
 - Compressor relay: N.O. 10A/250VAC
 - Light relay: N.O. 6A/250VAC

Front Panel Operation

1. Set temperature (compressor stop temperature) adjustment:
 - Press **SET** button, the set temperature is displayed.
 - Press **▲** or **▼** button to modify and store the displayed value. Press **SET** button to exit the adjustment and display the cold room temperature.
 - If no more button is pressed within 6 seconds, the cold room temperature will be displayed.
(Set temperature adjustment range:parameter E1~E2)
2. Light:Press **☹** button,it lights;Press again,it stops.
3. Refrigeration LED: During refrigeration, the LED is on; When the cold room temp. is constant, the LED is off; During the delay start, the LED flashes.
4. Parameter setup
 - Press **SET** button and hold for 6 seconds to enter the parameter setup mode while E1 flashes.
 - Press again **SET** button to select sequentially from the parameters : E2,E3,E4,E5,E1.
 - Press **▲** or **▼** button, the value of parameter will be displayed and can be modified and stored.
 - If no more button is pressed within 6 seconds, it will return to normal operation mode.

Parameter	Function	Set range	Default
E1	Lower setpoint limit	$-45^{\circ}\text{C} \sim \text{Set temp.}$	-35°C
E2	Higher setpoint limit	$\text{Set temp.} \sim 45^{\circ}\text{C}$	20°C
E3	Temp. hysteresis	$1 \sim 10^{\circ}\text{C}$	4°C
E4	Comp. start delay time	$0 \sim 10\text{Min}$	2Min
E5	Offset on room temp.	$-20 \sim 20^{\circ}\text{C}$	0°C

5. The factory default resumption: press **▼** button for 1 second and then press **▲** button simultaneously for 6 seconds, the LED flashes, all parameters will be resumed as same as factory defaults. After 6 seconds, it returns to the normal operation.
6. Lock parameters:
In normal operating,press **▼** button and hold for 6 seconds to lock the parameters if "OFF" is displayed (No modification is allowed),or to unlock if "ON" is displayed. Parameter can be displayed only and can not be modified if locked but the adiustment of the set temp. is still active (the factory default is "ON")

Function detail

1. Temperature control

- After turning on for the delay time ,the compressor starts operating when cold room temperature \geq (set temperature+ hysteresis), and will be off when cold room temperature \leq set temperature.
- To protect the compressor, it can re-start unless the time when the compressor stops every time is longer than the delay time(Parameter E4).

2. Defrosting Functions

- Operating after a defrost interval time (Parameter F2),it will automatically enter the status of defrost, and the compressor will stop. When the defrost duration ends, it will enter the normal status of refrigeration.
- When the defrost interval time is set to "00" , the function of automatic defrost will be cancelled. Press **SET** and **▽** button simultaneously and hold for 6 seconds to enter the parameter setup mode while F1 flashes. Press again **SET** button to select F1,F2. Press **△** or **▽** button, the value of parameter will be displayed and can be modified and stored.
- If no more button is pressed within 10 seconds, the cold-room temperature will be displayed.

Parameter	Function	Set range	Default
F1	Max. Defrost duration	1~90Min	20Min
F2	Defrost interval time	0~24Hr	0Hr

3. Abnormal work mode:

- When sensor is short-circuited or overheated (more than 100°C), "HH" is displayed; When sensor is open-circuited or temperature is too low (less than -45°C), "LL" is displayed. At that time the compressor automatically enters timing operation mode by the cycle of 45 minutes on and 15 minutes off.

4. Circuit Diagram:

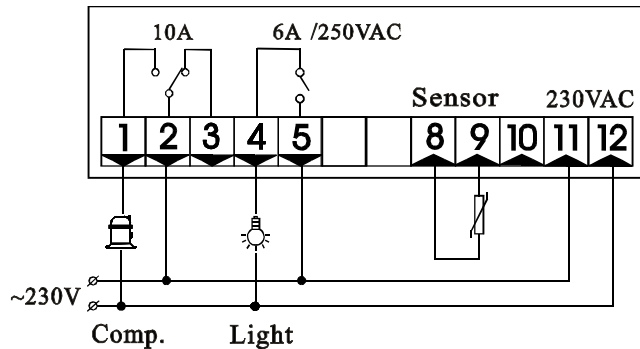

Notes for Installation

1. Sensor leads must be kept separately from main voltage wires in order to avoid high frequency noise induced. Separate the power supply of the loads from the power supply of the controller.
2. When installation the sensor shall be placed with the head upward and the wire downward.
3. In case of long-distance probe installation from the controller, the probe cable may be prolonged up to 100 m max. without any re-calibration
4. The temperature controller can not be installed in the area with water drops.

Accessories for the temperature controller

1. One temperature sensor
2. One installation stand
3. One cover panel