

# Photoelectric Beam Sensor ACTIVE INFRARED SENSOR

## Instruction Manual

ABT-30 (Outdoor 30m., Indoor 90m.)  
ABT-60 (Outdoor 60m., Indoor 180m.)  
ABT-80 (Outdoor 80m., Indoor 240m.)  
ABT-100 (Outdoor 100m., Indoor 300m.)

---

# 1 PARTS DESCRIPTION

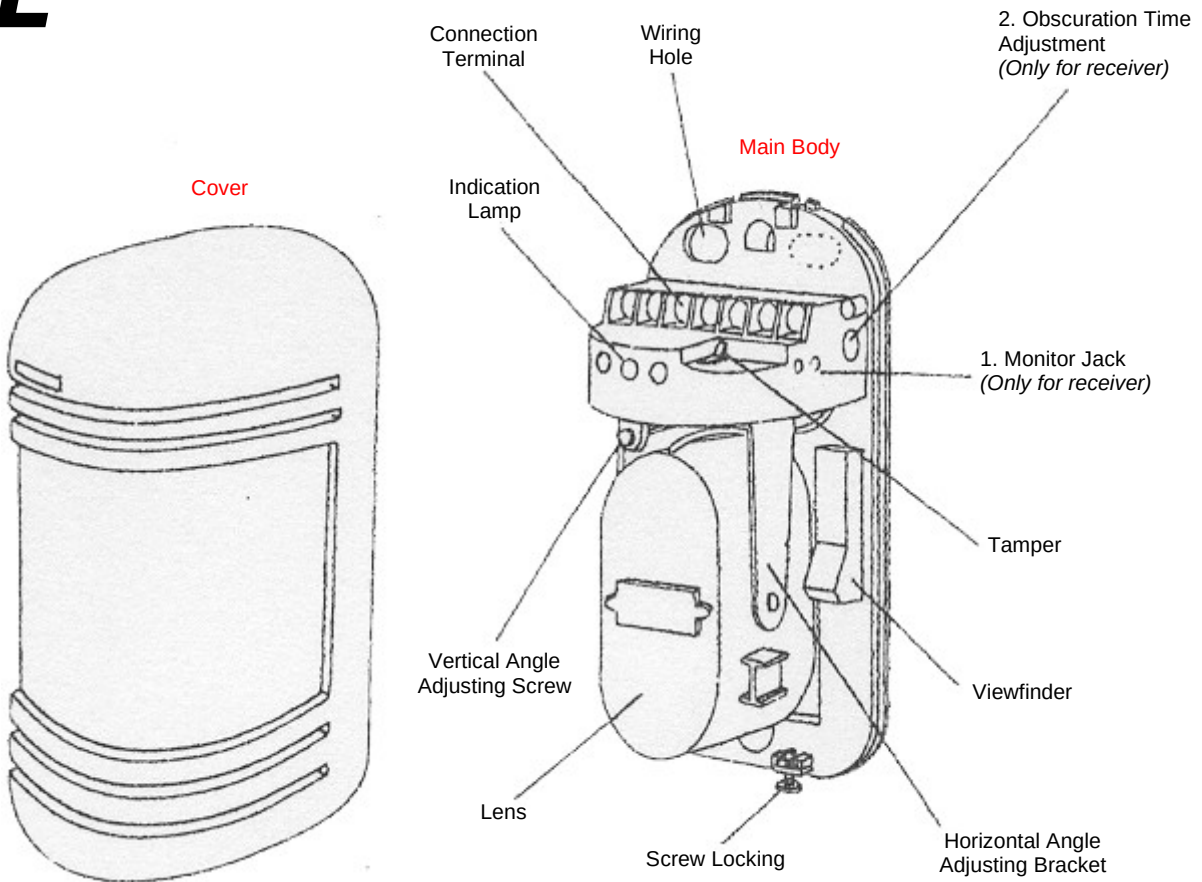

## 1. Indication Lamp

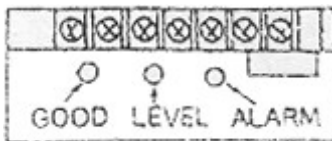

Receiver

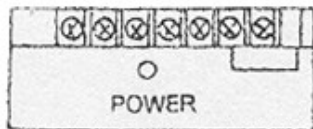

Transmitter

## Receiver:

- **Level (Red)**  
Brightness varies, depending on incident level.
- **Alarm (Red)**  
On indicated alarm.
- **Good (Green)**  
On indicates normal conditions, beam aligned.

1. **Monitor Jack:**  
Should be used for making the optimum optical axis adjustment. (Refer to "how to use monitor jack")
2. **Obscuration time adjustment:**  
To be used for setting the obscuration time to alarm. (Refer to "adjustment of obscuration time")

## Transmitter

- **Power (Green)**  
On indicates power is normal.

# 2 SUGGESTIONS FOR INSTALLATION

Do not install in the following conditions:

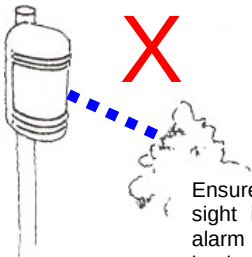

Ensure the sensor's line of sight is free from any false alarm sources such as bushes, trees, etc. (Pay attention to these as they may change seasonally).

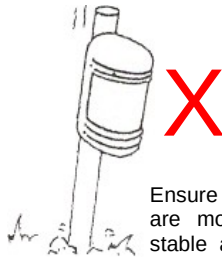

Ensure the sensors are mounted on a stable and firm footing.

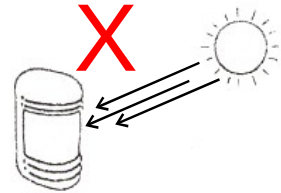

Ensure strong sunlight or car headlights do not shine directly on to the receiver. (Within  $\pm 2^\circ$  from the optical axis is not recommended).

Height of installation and protection distance:

Note that here the model references do not match the Protection Distance of Spread of Beam.

	Protection Distance	Spread of Beam
ABT-30	30 m	0.9 m
ABT-60	60 m	1.8 m
ABT-80	80 m	2.4 m
ABT-100	100 m	3.0 m

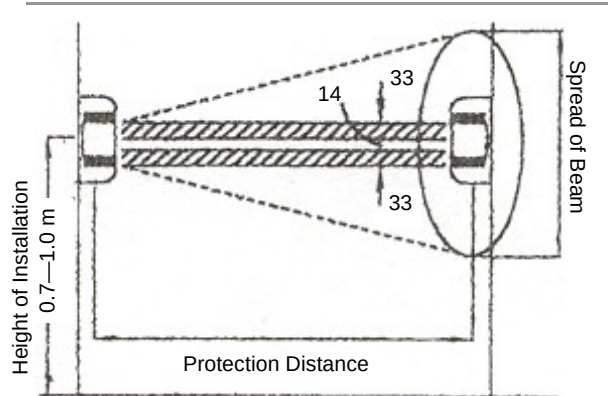

Direction of Installation:

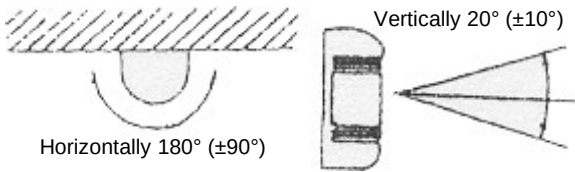

Because angle of reflection mirror is adjustable  $\pm 90^\circ$  horizontally and  $\pm 12^\circ$  vertically, the unit can be installed in various directions.

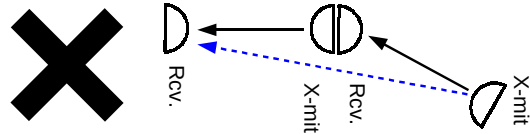

In case of jump phenomena as shown in the above sketch of long distance links, units are available with modified pulse frequencies on request.

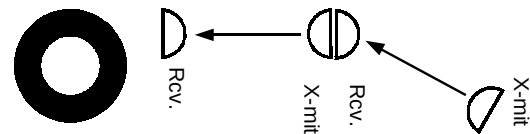

# 3 INSTALLATION

## Wall Mount:

1. Loosen screw holding cover and remove the cover.

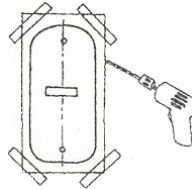
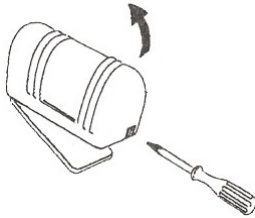

2. Attach the mounting pattern paper to the wall, mark the installation holes, and make the guide holes.

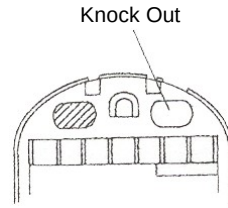

3. Break knock-out and pull wire through.

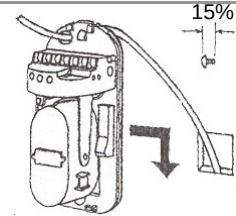

4. Attach the unit to the wall

5. Connect wires to the terminals.

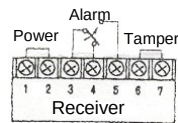
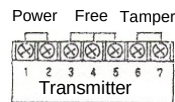
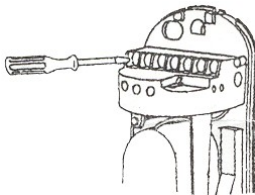

6. Make the optimum optical adjustment as per section 4, and confirm system operation before replacing covers.

Wiring Distance

Model	ABT-30		ABT-60		ABT-80		ABT-100	
	12 V	24 V	12 V	24 V	12 V	24 V	12 V	24 V
<b>Voltage</b>								
<b>Diameter of Wire</b>								
0.30 mm <sup>2</sup> (Ø0.6)	280 m	240 m	250 m	210 m	190 m	160 m	190 m	160 m
0.50 mm <sup>2</sup> (Ø0.8)	500 m	440 m	430 m	360 m	360 m	300 m	360 m	300 m
0.75 mm <sup>2</sup> (Ø1.0)	780 m	700 m	680 m	610 m	546 m	490 m	546 m	490 m
1.25 mm <sup>2</sup> (Ø1.2)	1120 m	1000 m	980 m	870 m	784 m	700 m	784 m	700 m

## Pole Mount:

(Suggested pole diameter Ø38 - Ø48 mm)

1. Pull the wire through the wire hole of the pole.
2. Route the wire through the main body of the detector and attach the detector to the flange.
3. Route the wire through the flange and attach the flange to the pole with the pole mounting bracket.
4. Attach the pole to the flange.

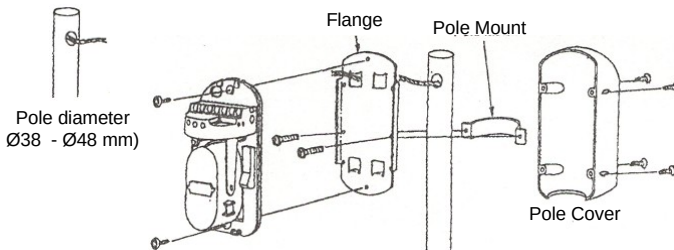

Back-to-back pole mounting.

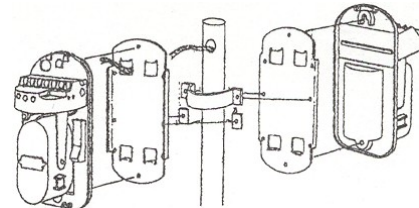

# 4 ADJUSTMENT OF OPTICAL AXIS (Aiming Beam)

1. Remove transmitter and receiver covers and apply power to the units.
2. In each unit, remove the viewfinder from its normal storage location and place it, as shown, on one of the holders on either side of the lens. Use whichever side permits sighting through the viewfinder in the next step.
3. At the transmitter, look through the viewfinder, with your eyes about 10 cm. From it. Adjust the horizontal angle bracket and (with a small screwdriver) the vertical angle screw. When the transmitter's optical axis is properly adjusted, the image of the receiver will be seen in the center of the viewfinder.

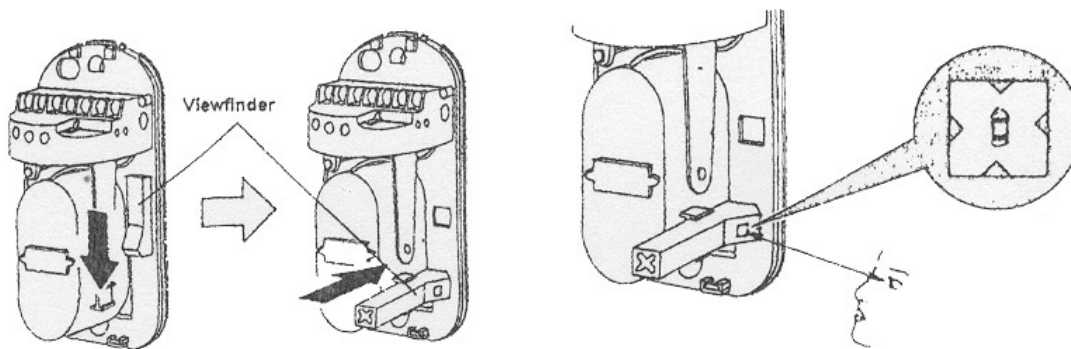

4. Repeat step 3, but at the receiver. When the transmitter's image is seen in the center of the receiver's viewfinder, the receiver's GOOD (green) monitor LED should be on as confirmation of proper alignment (if off, carefully repeat steps 3 and 4).

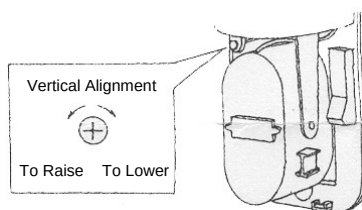

## NOTES:

The brightness of receiver's LEVEL (red) LED will vary with the accuracy of alignment. The better the alignment, the brighter the LED.

The best adjustment of optical axis can be done by reading the output voltage of the monitor jack.

1. Insert the meter pins into the monitor jack. (Pay attention to the polarity because of DC voltage.)
2. a) Adjust the horizontal angle bracket until the output is at maximum.  
b) Adjust the vertical angle screw to obtain maximum signal. (Do not interrupt beam by hands during the adjustment.)
3. The minimum voltage (2.3V) should be obtained to ensure best performance. (If this is not obtained then Transmitter and Receiver should be re-aligned.)

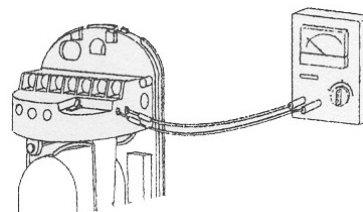



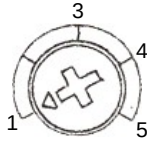

# 5 ADJUSTMENT OF SHADING TIME

Set the obscuration time of the receiver by adjusting the obscuration time control to the required setting according to the sketch to the right.

The obscuration time should be set lower to detect faster moving targets, however care should be taken to note the environmental conditions as the obscuration time should be set higher to ignore conditions where there are a lot of birds or wind-blown material.



Obscuration Time Control

Scale 1	Scale 2	Scale 3	Scale 4-5
			
Fast Running at Full Speed (6.9 m/s)	Walking with Quick Steps	Normal Walking (0.7 m/s)	Slow Action (0.3—0.5 m/s)

# 6 CONFIRM OPERATION

After completion of the installation, confirm correct operation by suitable walk tests. Refer to the following LED indications during the walk test.

Confirm Tamper operation prior to replacing covers.

Confirm system operation with covers replaced.

	Condition	Indication
Transmitter	Transmitting	Green LED is ON
Receiver	Watching	Alarm indicator is OFF
	Alarm	Alarm indicator is ON

# 7 TROUBLESHOOTING GUIDE

Symptom	Possible Cause	Remedy
Transmitter LED does not light.	Improper voltage supplied.	Check power supply and wiring.
Receiver power LED does not light.	Improper voltage supplied.	Check power supply and wiring.
Alarm LED does not light, even when beams are blocked.	Infrared beam from transmitter is reflecting from another object and is being sent into the receiver.	Remove reflecting object or change installation location and optical axis direction.
	Two beams are not blocked at the same time.	Check two beams to assure blocking at same time.
	Shorter blocking than the time set.	Adjust blocking time to be longer.
Although Alarm LED lights when beams are blocked, alarm doesn't sound.	Broken or shorted alarm output wires.	Check the wiring.
	Blown fuse on the signal circuit.	Repair as required.
Alarm LED on receiver does not turn off.	Optical axis not aligned.	Readjust the optical axis.
	Blocking object between transmitter and receiver.	Remove the blocking objects.
	Dirty cover or reflecting mirror at transmitter and/or receiver.	Clean optics with soft cloth.
Intermittent Alarm	Bad wiring connection.	Check wiring connection.
	Change of supply voltage.	Check for stabilized voltage.
	Blocking objects blowing between transmitter and receiver.	Remove blocking objects or change installation location.
	Unstable sensor mounting.	Stabilize mounting.
	Marginal optical axis alignment.	Readjust the optical axis.
	Birds or other large flying objects interrupting the beams.	Readjust blocking time or relocate installation.



# SPECIFICATIONS

Model		ABT-30	ABT-60	ABT-80	ABT-100
Protection Distance	Indoor	30 m	60 m	80 m	100 m
	Outdoor	90 m	180 m	240 m	300 m
Max. Arrival Distance		360 m	650 m	800 m	1100 m
Infrared Beam		2 Beams			
Detection System		Simultaneous cut-off of 2 beams			
Light Source		Infrared LED			
Response Time		50-700 m/sec			
Alarm Signal		Form 'C' (SPDT) relay contacts Rating: 0.5A max at 30 VAC, DC			
Supply Voltage		DC 10.5 - 28V			
Current Consumption		40 mA Max.	55 mA Max.	65 mA Max.	65 mA Max.
Temperature Range		-25°C - 55°C			
Dimensions (H X W X D)		171 X 82 X 77 mm			
Tamper Range		Form 'B' (SPST) relay contacts			
Optical Axis Adjustable Angle (Horizontal)		180° (±90°)			
Optical Axis Adjustable Angle (Vertical)		20° (±10°)			
Collimator		Viewfinder with peep window			
Measure for Moisture/Frost		Sit type cover			
Other Additional Functions		Alignment LED and Monitor Jack			
Material		ABS Plastic			
Weight		300 g (Transmitter & Receiver)			



# 9 OUTER DIMENSIONS

