

# **Weighing Indicator**

## **XK3190-A12**

### **User Manual**

---

# Content

CHAPTER 1 MAIN SPECIFICATION .....	-2-
CHAPTER 2 INSTALLATION .....	-3-
2.1 FRONT AND BACK VIEW OF INDICATOR .....	-3-
2.2 KEY FUNCTIONS .....	-4-
2.3 CONNECTING LOAD CELL TO INDICATOR.....	-4-
CHAPTER 3 OPERATION .....	-5-
3.1 POWER ON & ZERO SETTING.....	-5-
3.2 MANUAL ZERO SETTING.....	-5-
3.3 TARE .....	-5-
3.4 ACCUMULATING .....	-5-
3.5 COUNTING .....	-5-
3.6 USER FUNCTION STEETING .....	-6-
3.7 CONNECT SCOREBOARD TO INDICATOR .....	-6-
3.8 SERIAL COMMUNICATION AND INDICATOR COMMECTION .....	-8-
CHAPTER 4 CALIBRATION .....	-9-
CHAPTER 5 ERROR INDICATION .....	-10-
CHAPTER 6 CHARGEABLE BATTERY .....	-10-
CHAPTER 7 MAINTENTANCE .....	-11-

---

# Chapter 1 Main Specification

- |   |   |
|---|---|
| 1. Model :                              | XK3190 - A12 weighing indicator   |
| 2. Accuracy:                            | GradeIII, n=3000  |
| 3. Sample Rate :                        | 10 times / second   |
| 4. Load cell sensitivity :              | 1.5 ~ 3mV / V   |
| 5. Scale interval :                     | 1/2/5/10/20/50 for option   |
| 6. Display :                            | 6 bits LCD , 6 state indicating signals                                     |
| 7. Scoreboard interface (optional) :    | In serial output mode : current loop signal,<br>transmission distance≤50m , |
| 8. Communication interface (optional) : | RS232C ; Baud rate 1200/2400/4800/9600 optional                             |
| 9. Power supply:                        | Battery DC6V/4AH  |
| 10. Operating temperature/humidity:     | 0 ~ 40°C ; ≤90%RH   |
| 11. transporting temperature:           | -20 ~ 50°C  |

---

# Chapter 2 Installation

## 2.1 FRONT AND BACK VIEW OF THE INDICATOR

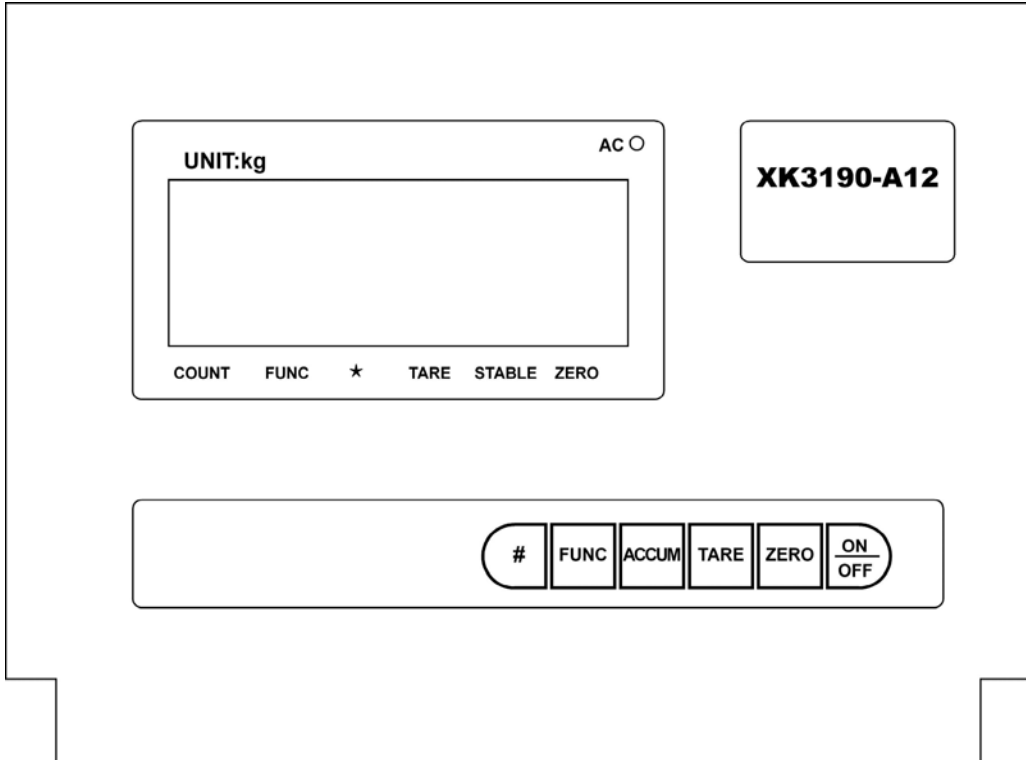

**Front View**

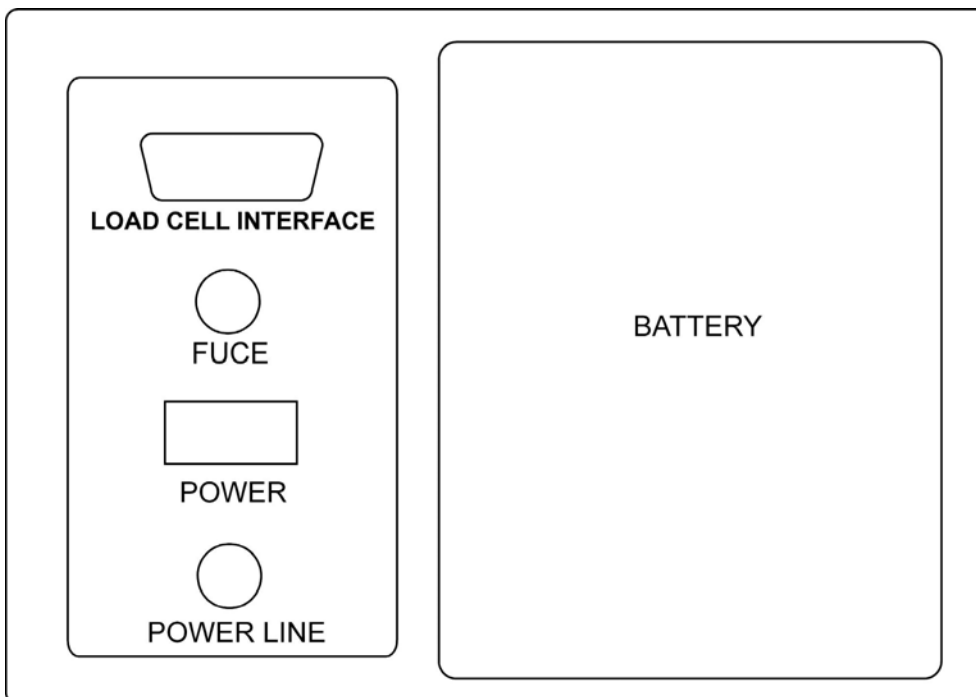

**Back View**

## 2.2 KEY FUNCTIONS

- [FUNC ]** Keep pressing this button for 5 seconds more in weighing mode, it will come into operator setting mode; less than 5 seconds, it will come into counting mode.
- [ACCUM ]** Press this button to accumulating the weight in weighing mode.  
Press this button for sample taking in counting mode
- [TARE ]** Press this button to tare in weighing mode.
- [ZERO ]** Press this button to zero in weighing mode.
- [ON/OFF ]** Press this button to start the indicator when it is off; and press it to shut off upon on.

## 2.3 CONNECTING LOAD CELL TO INDICATOR

1. The 9-pin socket is used for the link-up of load cell, which has been clearly shown in the graph 2-3.
2. The 4-pin shielded cable is used, and the indicator does not have the function of long distance compensation.
- 3. Indicator must be reliably connected to Load cell and shielded-cable of load cell must be reliably connect ed to underground. If indicator is powered on, the user should not insert or withdraw the plug in order to protect the indicator and load cell.
- 4. Sensor and indicator are static sensitive devices; you must adopt anti-static measures. The electric welding operation and other strong electric operation are prohibited. In order to protect the operator, indicator, and relevant devices, you should install lightning rod in the thunderstorm frequently happening area

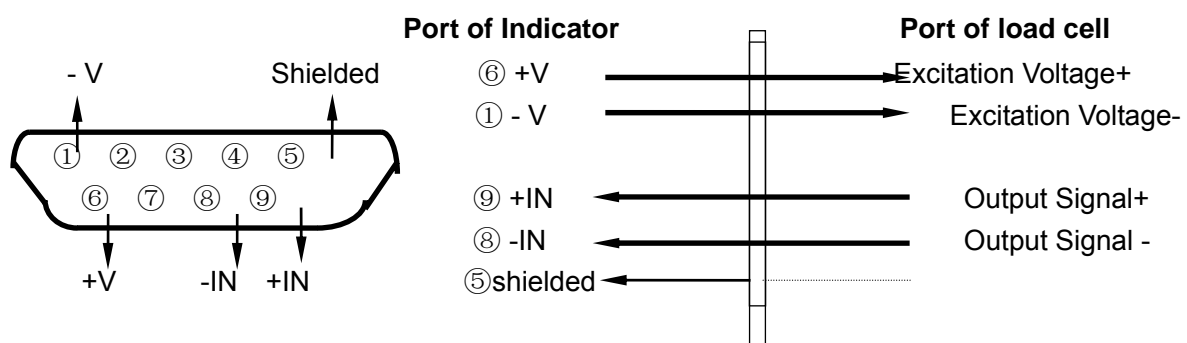

(Graph 2-3) Drawing of connecting of load cell

---

# Chapter 3 Operation

## 3.1 POWER ON AND AUTO ZERO-SETTING

3.1.1 The indicator will perform “999999-000000” to self-checking when turning on. Then it will enter weighing mode.

3.1.2 When power on, if loading weight on the scale deviates from the zero point, but still within zero set range, the indicator will set zero automatically; if out of range, it is necessary to adjust the zero point or recalibrate or reset.

## 3.2 MANUAL ZERO SETTING (AUTOMATICALLY)

3.2.1 In weighing mode, when there is some error when unloaded, press **[Zero]** to make the indicator to be zero.

3.2.2 If the displayed value deviates from zero point, but still within zero-range, pressing **[Zero]** key is available. Otherwise, **[Zero]** key is invalid. (In this status, please recalibrate or reset zero parameters)

3.2.3 Only when stable annunciator is on, zero operation can be available.

## 3.3 TARE FUNCTION

When Indicator at weighing status, and displaying positive weight stable, press **[ Tare ]** key, indicator will deduct the displayed weight value as tare weight. Then indicator displays net weight as “0”, and Tare sign annunciator is on.

## 3.4 ACCUMULATING FUNCTION

In weighing mode, when the displayed value is positive and stable as well, press **[Accum]** key to accumulate the present weight and display the accumulated weight, the accumulate annunciator will be on. Press this key again, it will back to weighing mode and the accumulate annunciator will be off. The next accumulating operation must be performed after the weight return to be zero. When the accumulated weight displayed, press **[Func]** key to clean the accumulated weight in Memory and press **[Accum]** to return weighing mode. If the accumulated weight needs to be checked, please keep the load of platform to be zero, then press **[Accum]** to display the accumulated weight.

## 3.5 COUNTING FUNCTION

In weighing mode, press **[Func]** to enter the counting state, it will display “count”, and press **[Accum]** it will display “C00000”, then press **[Tare]** to move the digit corresponding with the small triangle, the number corresponding with the small triangle will be increased one by one each time after pressing **[Zero]** key; and it will enter counting function after the sample number inputted and **[Accum]** pressed. “0” will be displayed and the counting annunciator will be on. Press **[Func]** key to return weighing mode. After entering counting mode, “count” will be displayed, press **[Accum]** twice times to enter counting mode directly, indicator will display according to the result of the sampling last time. (In this process, if the ERR4 appears, it means sampling failed, the indicator will keep the result from the last sampling)







---

### 3.8 SERIAL COMMUNICATION AND INDICATOR CONNECTION

- Make sure that communication interface output lead and computer are correctly connected, if there is something wrong with connection, damage will happen to output port of instrument and input port of computer, sometimes, the damage is so big that instrument, computer and corresponding peripherals are got involved.
- Necessary computer technology and programming expertise are required for computer communication, which should be participated and instructed by professionals. Non-professional staff is supposed not to be involved in this regard.

With RS232(optional) serial communication interface, the XK3190-A12 indicator can be connected to computer for communication.

1. All data are ASCII code, every set of which is composed of 10 bits: the 1<sup>st</sup> is starting bit, the 10<sup>th</sup> is stop bit, the middle in between are 8 data bits.

#### Communication mode as follows:

- (1). In continuous mode:

The data transmitted is weight (Gross weight or net weight)

The format of G.W. : ww000.000kg or ww000.000lb

The format of N.W : wn000.000kg or wn000.000lb

Note : The position of above decimal is decided by the decimal set on the indicator.

- (2). In command mode:

The indicator performs the corresponding operation according to the command transmitted from the indicator.

**Command R** The indicator receives and sends weight data once time (the format is the same as the continuous mode)

**Command T** The indicator receive the command and tare (the same as tare key); if no receipt of the command. The indicator returns CR LF

**Command Z** The indicator receives the command and zero (the same as zero key); if no receipt of the command, the indicator returns CR LF.

## Chapter 4 Calibration

4.1 Connect load cell properly, then turn on the indicator, press [#] key while it is initialization, it will enter into the calibration mode and calibrate as following:

STEP	OPERATION	DISPLAY	NOTES
1	Press [TARE] for selection of division	[d X ]	Select division optional(1/2/5/10/20/50),press [#] for confirm Example: 20
2	Press [TARE] for selection of DECIMAL POINT selection	[P X ]	Select decimal point optional: 0~3, press [#] for confirm Example:3
3	Set the full range	[FULL ]	Press [TARE] for selection of the digit bit; Press [ZERO] for selection of the digit; Press [#] for confirm the input of full range
4	Zero point calibration: Press [#] when the stable signal is on	[nOLOAD]	Assure there is no load
5	Full range point calibration: Press [#] when the value input is the same as the loaded weight and the stable signal is on	[AdLOAD]	While inputting the loaded weight, Press [TARE] for selection of the digit bit; Press [ZERO] for selection of the digit; when the input value is the same as the loaded weight and the digit bit is at the highest bit, press [#] when the stable signal is on
6		[ End]	
7	Press the calibration switch under the lead sealing board at the back of the indicator		It saves the calibration parameter and back to the weighing status. Attention: if no pressing the calibration switch, all the parameters won't be saved.

### 4.2 FAST CALIBRATION FOR ZERO POINT AND FULL RANGE POINT

Press [#] while it is initialization, it enters into the calibration mode.

#### 4.2.1 Fast calibration for zero point:

At any time before it shows [nOLOAD], press [FUNC], it keeps the original division, decimal point, full range and enter into the zero point calibration mode. Press [ZERO] when the stable signal is on, it displays [End] and keeps the original full range point calibration. Press the calibration switch under the lead sealing board at the back of the indicator, it saves the setting and back to the weighing status.

---

#### 4.2.2 Fast calibration for full range point:

At any time before it shows [AdLOAD], press [ACCU], it keeps the original division, decimal point, full range, zero point calibration and enter into the full range point calibration mode. When it is finished, press the calibration switch under the lead sealing board at the back of the indicator, it saves the setting and back to the weighing status.

## Chapter 5 Error Indication

<b>EER 1</b>	The AD value is too small when calibrated.
<b>EER 2</b>	The zero point is out of range when calibrated.
<b>EER 3</b>	The zero point is out or range upon starting
<b>EER 4</b>	The imputed sample number is zero when sampling n counting mode.
<b>EER 5</b>	The imputed weight is zero when full scale calibrated in calibrating mode.
<b>EER 6</b>	The unit weight is less than 0.25e when sampling in counting mode
<b>bAt-lo</b>	Low power

## Chapter 6 Chargeable Battery

6.1 Turing on the AC power, the indicator will charge the battery automatically. So if you don't use battery frequently, you should take battery out.

■ Note: red end is +, black end is -. Wrong connection will destroy indicator.

■ Note: The built-in battery should be fully charged before it is used for the first time.

6.2 Only when you turn off the AC power, and push start key, battery works. Displaying [LuoL] means the insufficient of voltage, it needs charge.

6.3 When you use the battery first time, you should charge the battery for 20 hours in order to prevent low voltage resulted from the self leakage of the battery.

6.4 If you don't use battery for a long time, you should charge the battery for 10-12 hours for each 2 month to prolong using life of battery.

6.5 The battery is easily exhausted products. And it is not granted free guarantee.

---

# Chapter 7 Maintenance

- 7.1 To guarantee indicator clarity and using life, the indicator shouldn't be placed directly under sunshine and should be set in the plain space.
- 7.2 The indicator can't be placed into the place where the dust pollution and vibration are serious.
- 7.3 Load cell should connect with indicator reliably, and the system should be well connected into ground. The indicator must be protected from high electrical field and high magnetic field.
- In order to protect the operator, indicator and relevant device, you should mount lightning rod in thunderstorm frequently happening area.
  - Load cell and indicator are static sensitive device, you must adopt anti static measures.
- 7.4 It is strictly forbidden to clean the case of indicator with intensive solvents (for example: benzene and nitro oils)
- 7.5 Liquid and conducting particle should not be poured into the indicator, otherwise the electronic components will be damaged and electric shock is likely to happen.
- 7.6 You should cut off power supply of indicator and relevant device before you pull-in and out the connecting line of indicator and external device.
- You must cut off power supply of indicator, before pulling out connecting line of load cell.
- 7.7 During operation, if trouble occurs, operator must pull off the power supply plug immediately, and user should return this indicator to our company for repair. Non-weighing manufacturer should not repair it, or by yourself, otherwise further destruction may happen.
- 7.8 The storage is not granted the free repair guarantee, because it is easily exhausted products.
- In order to prolong using life, please charge the cell fully before using it. If you don't use the indicator for a long time, you must charge the cell every two month and for eight hours/each charging time.
  - Moving or installation must be carefully taken and must avoid strong vibration, impact and bump in order to protect the storage cell from being damaged.
- 7.9 From invoice date, the indicator has a one-year free repair period. If any non-artificially obstacle about the indicator happens under correct using conditions within this period, the user is allowed to send the product with its guarantee card (of the correct number) back to our corporation for free repair. The indicator shouldn't be taken apart, otherwise free guarantee will be cancelled.