

Motor Specification

Motor Model	Step Angel (°)	Motor Length L (mm)	Holding Torque (Nm)	Phase Current (A)	Phase Inductance (mH)	Weight (kg)
110J12160EC-1000	1.2	158	16Nm	6.0A	19mH	14.8kg
110J12190EC-1000	1.2	192	20Nm	6.8A	22mH	19.8kg

Motor Dimensions

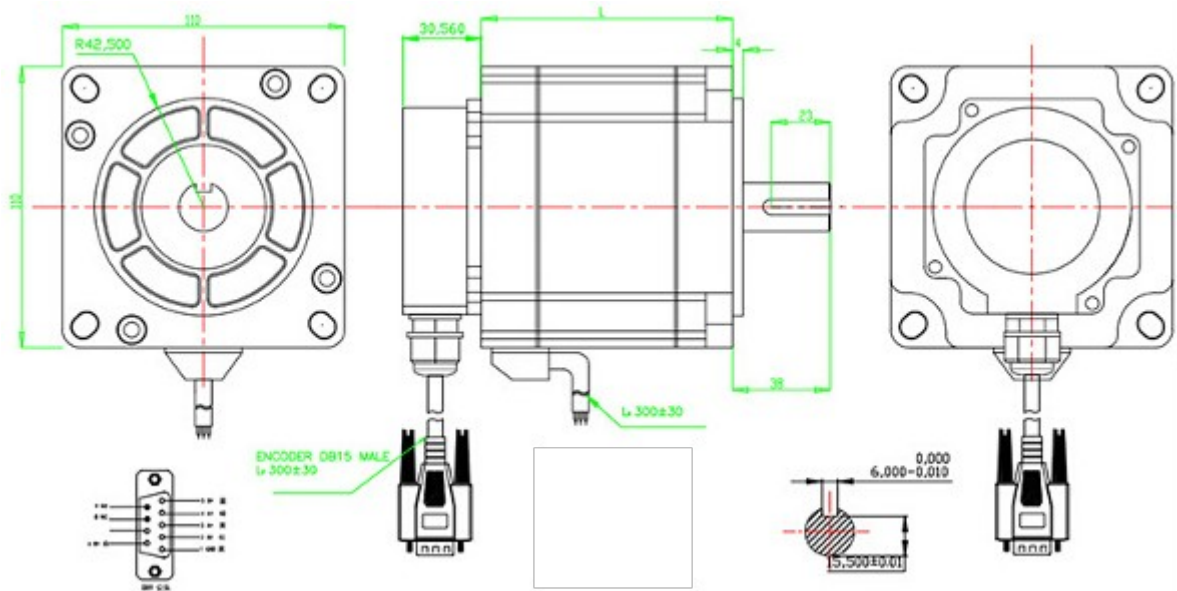

ENCODER

COLOR	DESCRIPTION
RED	+5V DC
BLACK	GROUND
YELLOW	CHANNEL A+
GREER	CHANNEL A-
ORANGE	CHANNEL B+
BROWN	CHANNEL A-

